

Hypertherm®





















HySpeed® Plasma HSD130™

Consumables



























HySpeed Plasma
HSD130















Mild steel

	Shield	Retaining cap	Nozzle	Swirl ring	Electrode
45A (Air)	 220532	 220578	 220525	 220529	 220528
50A (O ₂)	 220532	 220578	 220530	 220529	 220528
130A (Air)	 220536	 220578	 220492	 220488	 220487
130A (O ₂)	 220491	 220578	 220489	 220488	 220487

Stainless steel

	Shield	Retaining cap	Nozzle	Swirl ring	Electrode
45A (Air)	 220532	 220578	 220525	 220529	 220528
45A (N ₂ and F5)	 220532	 220534	 220525	 220529	 220528
130A (Air)	 220536	 220578	 220492	 220488	 220487
130A (N ₂)	 220536	 220578	 220535	 220488	 020415
130A (H35)	 220536	 220534	 220535	 220529	 020415

Aluminum

	Shield	Retaining cap	Nozzle	Swirl ring	Electrode
45A (Air)	 220532	 220578	 220525	 220529	 220528
130A (Air)	 220536	 220578	 220492	 220488	 220487
130A (H35)	 220536	 220534	 220535	 220529	 020415



HySpeed Plasma
HSD130 torch

HSD130 consumables

MATERIAL	CONSUMABLE DESCRIPTION	45 AMPS	50 AMPS	130 AMPS
Mild steel	Electrode	220528	220528	220487
	Swirl ring	220529	220529	220488
	Nozzle	220525	220530	220489 (O ₂)
		-----	-----	220492 (Air)
		-----	-----	220491 (O ₂)
	Shield	220532	220532	220536 (Air)
	-----	-----	-----	220536 (Air)
Retaining Cap	220578	220578	220578	
Stainless steel	Electrode	220528	-----	220487 (Air)
	-----	-----	-----	020415 (N ₂ , H35)
	Swirl ring	220529	-----	220488 (Air)
		-----	-----	220488 (N ₂)
		-----	-----	220529 (H35)
	Nozzle	220525	-----	220492 (Air)
		-----	-----	220535 (N ₂ , H35)
		-----	-----	220536 (Air)
	Shield	220532	-----	220536 (Air)
	-----	-----	-----	220536 (N ₂ , H35)
Retaining Cap	220578 (Air)	-----	220578 (Air)	
	220534 (N ₂ , F5)	-----	220534 (H35)	
	-----	-----	220578 (N ₂)	
Aluminum	Electrode	220528	-----	220487 (Air)
	-----	-----	-----	020415 (H35)
	Swirl ring	220529	-----	220488 (Air)
		-----	-----	220529 (H35)
		-----	-----	220492 (Air)
	Nozzle	220525	-----	220535 (H35)
		-----	-----	220536 (Air)
-----		-----	220536 (H35)	
Shield	220532	-----	220536 (Air)	
-----	-----	-----	220536 (H35)	
Retaining Cap	220578	-----	220578 (Air)	
	-----	-----	220534 (H35)	

HSD130 torch assembly

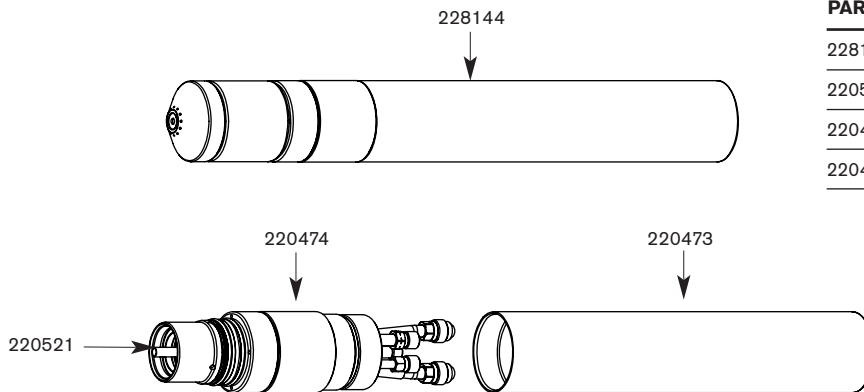

PART NO.	DESCRIPTION
228144	Torch assembly (includes consumables and sleeve)
220521	Water tube
220474	Torch main body
220473	Torch mounting sleeve

Hypertherm and HySpeed are trademarks of Hypertherm, Inc., and may be registered in the United States and/or other countries.

Hypertherm®

Hypertherm, Inc.
Hanover, NH 03755 USA
603-643-3441 Tel

Hypertherm (S) Pte Ltd.
417847, Republic of Singapore
65 6 841 2489 Tel

Hypertherm (Shanghai) Trading Co., Ltd.
PR China 200052
86-21 5258 3330 /1 Tel

Hypertherm Europe B.V.
4704 SE Roosendaal, Nederland
31 165 596907 Tel

HYPERTHERM BRASIL LTDA.
Guarulhos, SP - Brasil
55 11 6409 2636 Tel

www.hypertherm.com